



23

## Adapter sleeves



# 23 Adapter sleeves

<b>Designs and variants</b> .....	<b>1067</b>
Sleeves for oil injection .....	1068
Sleeves for CARB toroidal roller bearings .....	1069
Sleeves for sealed bearings .....	1069
<b>Product data</b> .....	<b>1070</b>
(Dimension standards, tolerances, external taper, thread, shaft tolerances)	
<b>Designation system</b> .....	<b>1071</b>
<b>Product tables</b>	
<b>23.1</b> Adapter sleeves for metric shafts .....	1072
<b>23.2</b> Adapter sleeves with inch dimensions. ....	1076

# 23 Adapter sleeves

## More information

SKF maintenance products

→ [skf.com/mapro](https://skf.com/mapro)

SKF bearing maintenance handbook ISBN 978-91-978966-4-1

Adapter sleeves are the most commonly used components for locating bearings with a tapered bore onto a cylindrical seat as they can be used on (fig. 1):

- plain shafts
- stepped shafts

They are easy to install and require no additional location on the shaft:

- When used on plain shafts, the bearing can be located at any position on the shaft.
- When used on stepped shafts together with an L-shaped spacer ring, the bearing can be accurately positioned axially, thereby facilitating bearing mounting and dismounting.

Fig. 1

### Adapter sleeve assemblies

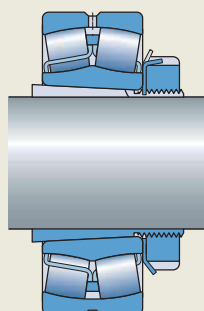

On a plain shaft

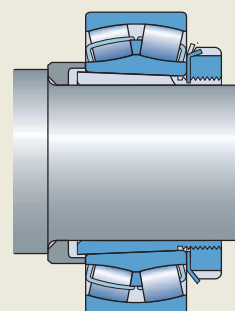

On a stepped shaft

# Designs and variants

SKF supplies:

- metric adapter sleeves
  - with a metric bore
  - with an inch bore

These sleeves are not listed in this catalogue, but can be found online at

[skf.com/go/17000-23-3](https://skf.com/go/17000-23-3).

- inch adapter sleeves

Inch sleeves are coated with a solventless rust inhibitor.

Adapter sleeves listed in the [product tables, page 1072](#), constitute the standard SKF assortment and are only part of the complete assortment. For larger sizes (bore diameter  $\geq 1\,060$  mm) and variants not listed, contact SKF.

The sleeves are slit and are supplied complete with a lock nut and locking device ([fig. 2](#)):

- Smaller sizes have a nut and a lock washer.
- Larger sizes have a nut and a locking clip or locking plate.

Metric sleeves:

- with a bore diameter  $\leq 180$  mm (size  $\leq 40$ ) are phosphated
- with a bore diameter  $> 180$  mm are coated with a solventless rust inhibitor

Fig. 2

## Basic designs

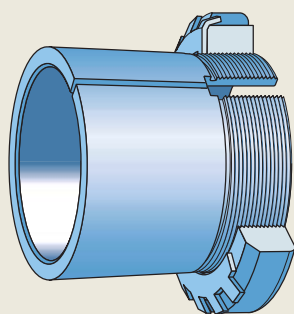

Sleeve with a nut and washer

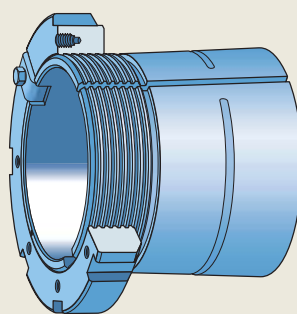

Sleeve with a nut and clip

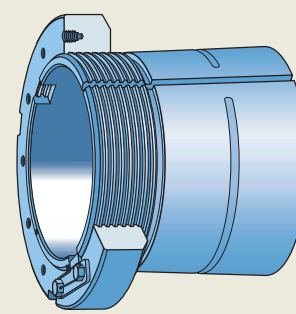

Sleeve with a nut and plate



# Sleeves for oil injection

- enable use of the oil injection method to mount and dismount bearings
- are equipped with the necessary oil supply ducts and distribution grooves
  - as standard for metric sleeves with a bore diameter  $\geq 200$  mm (size  $\geq 44$ )
  - on request for metric sleeves with a bore diameter  $\geq 140$  mm to  $< 200$  mm
  - on request for inch sleeves with a bore diameter  $\geq 4 \frac{5}{16}$  inches (size  $\geq 26$ )
- include OH (metric) series, and OSNW and OSNP (inch) series

Thread details for the oil supply ducts and the appropriate hydraulic nut designations are listed in the [product tables, page 1072](#).

For information about oil injection equipment, refer to the catalogue *SKF Maintenance and Lubrication Products* or online at [skf.com/mapro](http://skf.com/mapro).

SKF manufactures sleeves for oil injection in four variants ([table 1](#)). Those with a designation suffix H are the SKF standard.

Table 1

Adapter sleeves for oil injection

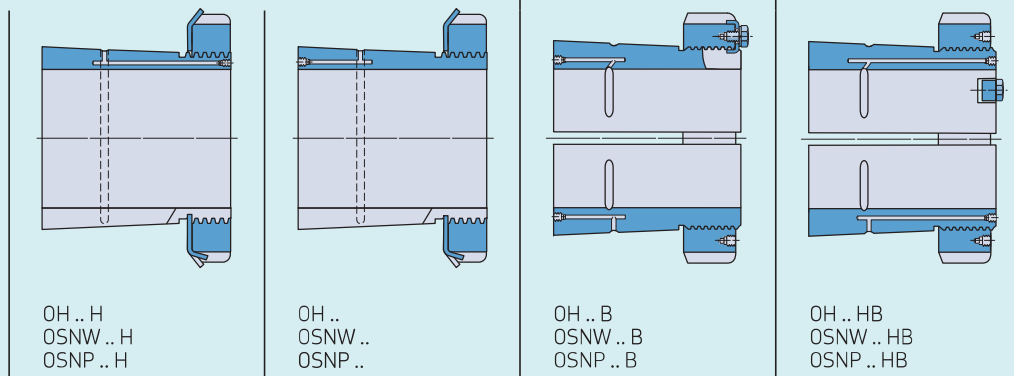

	OH .. H OSNW .. H OSNP .. H	OH .. OSNW .. OSNP ..	OH .. B OSNW .. B OSNP .. B	OH .. HB OSNW .. HB OSNP .. HB
<b>Designation suffix</b>	H	None	B	HB
<b>No. of oil supply ducts<sup>1)</sup> for:</b>				
• all sleeves with a bore diameter $< 200$ mm	1	1	1	1
• metric sleeves with a bore diameter $\geq 200$ mm	1	1	2	2
• inch sleeves with a bore diameter $\geq 4 \frac{5}{16}$ inches (made to order)	1	1	2	2
<b>Position of oil supply duct(s)</b>	At the threaded end of the sleeve	At the end opposite the threaded section	At the end opposite the threaded section	At the threaded end of the sleeve
<b>Position of distribution groove(s)</b>	In the outside surface	In the outside surface	In the bore and in the outside surface	In the bore and in the outside surface

<sup>1)</sup> When sleeves have two supply ducts, each duct feeds one of the distribution grooves. An arrow on the sleeve side face, next to the duct inlet, indicates which groove the duct feeds.

## Sleeves for CARB toroidal roller bearings

- are specially designed to prevent the locking device from interfering with the cage

SKF manufactures sleeves for CARB toroidal roller bearings in three variants (fig. 3):

- **Sleeves with the designation suffix E**
  - are supplied with a KMFE lock nut in place of the standard KM lock nut and MB lock washer
  - are supplied with an HME lock nut in place of the standard HM 30 or HM 31 lock nut
- **Sleeves with the designation suffix L**
  - are supplied with a KML lock nut and MBL lock washer, both with low cross-sectional height, in place of the standard KM lock nut and MB lock washer
- **Sleeves with the designation suffix TL**
  - are supplied with an HM 30 lock nut and MS 30 locking clip, both with low cross-sectional height, in place of the standard HM .. T lock nut and MB lock washer

When using CARB bearings, check that there is sufficient space on both sides of the bearing to accommodate axial displacement.

## Sleeves for sealed bearings

- are specially designed to prevent the locking device from interfering with the seals of sealed spherical roller bearings and sealed self-aligning ball bearings
- have the designation suffixes E, EL, EH, L, and TL (fig. 3 and fig. 4)

Adapter sleeve assemblies with the designation suffix EL or EH are supplied with one of the following, respectively:

- a KMFE .. L lock nut, which has a lower abutment diameter than the standard KMFE lock nut
- a KMFE .. H lock nut, which has a higher abutment diameter than the standard KMFE lock nut

Fig. 4

Adapter sleeve assemblies for sealed bearings (with a KMFE lock nut)

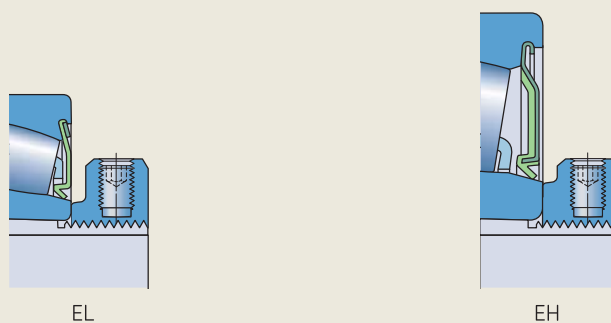
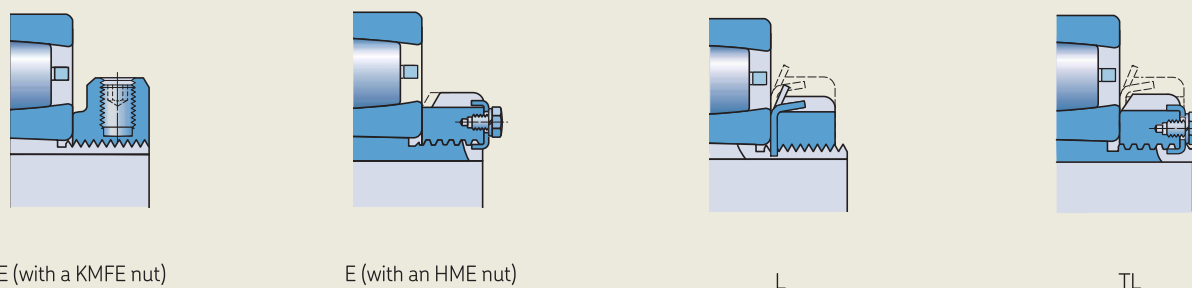

Fig. 3

Adapter sleeve assemblies for CARB toroidal roller bearings



## Product data

	Metric series	Inch series
<b>Dimension standards</b>	ISO 2982-1, except for the bore diameter of sleeves for inch shafts	ANSI/ABMA Std. 8.2
<b>Tolerances</b>	Bore diameter: JS9 Width: h15	
<b>External taper</b>	1:12 as standard 1:30 as standard in the 40 and 41 dimension series	
<b>Thread</b>	<p><b>Bore diameter &lt; 200 mm (size ≤ 40):</b> metric thread in accordance with ISO 965-3, matching the included SKF lock nut</p> <p><b>Bore diameter ≥ 200 mm (size ≥ 44):</b> metric trapezoidal thread in accordance with ISO 2903, matching the included SKF lock nut</p>	<p><b>Bore diameter ≤ 12 in. (size ≤ 64):</b> Unified Special Form ANSI/ASME B1.1</p> <p><b>Bore diameter ≥ 12 7/16 in. (size ≥ 68):</b> ACME thread class 3G</p>
<b>Shaft tolerances</b>	<p>h9<sup>Ⓢ</sup> Total radial run-out: IT5/2 – ISO 1101</p> <p>Adapter sleeves adjust to the shaft diameter so that wider diameter tolerances can be permitted compared to the seat of a bearing with a cylindrical bore. However, the geometrical tolerances must be kept within narrow limits as they directly affect the shaft positioning and vibration.</p>	

# Designation system



## Product type

<b>H</b>	Adapter sleeve, dimensions in accordance with ISO standard, basic design
<b>HA</b>	Adapter sleeve, dimensions in accordance with ISO standard, except the bore, in 1/16 in.
<b>HE</b>	Adapter sleeve, dimensions in accordance with ISO standard, except the bore, in 1/4 in.
<b>HS</b>	Adapter sleeve, dimensions in accordance with ISO standard, except the bore, in 1/8 in.
<b>OH</b>	Adapter sleeve, dimensions in accordance with ISO standard, prepared for oil injection
<b>OSNP</b>	Adapter sleeve, dimensions in accordance with ANSI standard, prepared for oil injection, with a locking plate
<b>OSNW</b>	Adapter sleeve, dimensions in accordance with ANSI standard, prepared for oil injection, with a lock washer
<b>SNP</b>	Adapter sleeve, dimensions in accordance with ANSI standard, with a locking plate
<b>SNW</b>	Adapter sleeve, dimensions in accordance with ANSI standard, with a lock washer
<b>KH</b>	Unthreaded sleeve, basic design
<b>KOH</b>	Unthreaded sleeve, prepared for oil injection

## Size identification

Listed in the [product tables, page 1072](#)

## Suffixes

<b>B</b>	For adapter sleeves for oil injection: One or two oil supply ducts at the end opposite the threaded section For adapter sleeves for inch shafts: Whitworth thread
<b>D</b>	Sleeve split in two halves
<b>E</b>	Adapter sleeve without key slot, with a KMFE lock nut or standard adapter sleeve with an HME lock nut
<b>EH</b>	Adapter sleeve without key slot, with a KMFE .. H lock nut
<b>EL</b>	Adapter sleeve without key slot, with a KMFE .. L lock nut
<b>G</b>	Thread diameter changed according to revised ISO standard
<b>H</b>	One oil supply duct at the threaded end
<b>HB</b>	One or two oil supply ducts at the threaded end
<b>L</b>	Adapter sleeve with a lock nut with lower cross-sectional height
<b>TL</b>	Same as L, but with key slot positions for a locking clip

## 23.1 Adapter sleeves for metric shafts

$d_1$  17 – 180 mm

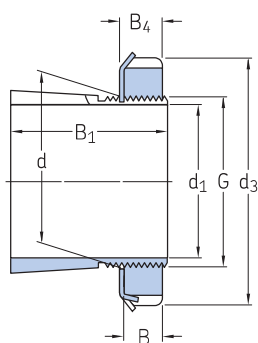

H

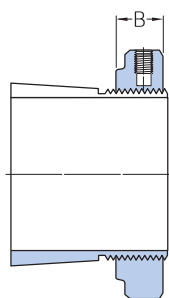

H..E

Principal dimensions											Mass	Designations			
$d_1$	d	$d_3$	$B_1$	B	$B_4$	$B_5$	G	$G_2$	$G_3$	A		Adapter sleeve assembly	Included products lock nut	locking device	Associated hydraulic nut
mm											kg	–			
17	20	32	24	6	7	–	M 20x1	–	–	–	0,036	▶ H 204	KM 4	MB 4	–
	20	32	28	6	7	–	M 20x1	–	–	–	0,04	▶ H 304	KM 4	MB 4	–
	20	38	28	10,5	–	–	M 20x1	–	–	–	0,047	▶ H 304 E	KMFE 4	–	–
20	25	38	26	7	8	–	M 25x1,5	–	–	–	0,064	▶ H 205	KM 5	MB 5	–
	25	38	29	7	8	–	M 25x1,5	–	–	–	0,071	▶ H 305	KM 5	MB 5	–
	25	38	29	10,5	–	–	M 25x1,5	–	–	–	0,076	▶ H 305 E	KMFE 5	–	–
25	30	45	27	7	8	–	M 30x1,5	–	–	–	0,086	▶ H 206	KM 6	MB 6	–
	30	45	31	7	8	–	M 30x1,5	–	–	–	0,095	▶ H 306	KM 6	MB 6	–
	30	45	31	10,5	–	–	M 30x1,5	–	–	–	0,11	▶ H 306 E	KMFE 6	–	–
30	35	52	29	8	9	–	M 35x1,5	–	–	–	0,12	▶ H 207	KM 7	MB 7	–
	35	52	35	8	9	–	M 35x1,5	–	–	–	0,14	▶ H 307	KM 7	MB 7	–
	35	52	35	11,5	–	–	M 35x1,5	–	–	–	0,15	▶ H 307 E	KMFE 7	–	–
35	40	58	31	9	10	–	M 40x1,5	–	–	–	0,16	▶ H 208	KM 8	MB 8	–
	40	58	36	9	10	–	M 40x1,5	–	–	–	0,17	▶ H 308	KM 8	MB 8	–
	40	58	36	13	–	–	M 40x1,5	–	–	–	0,19	▶ H 308 E	KMFE 8	–	–
40	45	65	33	10	11	–	M 45x1,5	–	–	–	0,21	▶ H 209	KM 9	MB 9	–
	45	65	39	10	11	–	M 45x1,5	–	–	–	0,23	▶ H 309	KM 9	MB 9	–
	45	65	39	13	–	–	M 45x1,5	–	–	–	0,24	▶ H 309 E	KMFE 9	–	–
45	50	70	35	11	12	–	M 50x1,5	–	–	–	0,24	▶ H 210	KM 10	MB 10	HMV 10E
	50	70	42	11	12	–	M 50x1,5	–	–	–	0,27	▶ H 310	KM 10	MB 10	HMV 10 E
	50	70	42	14	–	–	M 50x1,5	–	–	–	0,3	▶ H 310 E	KMFE 10	–	HMV 10 E
50	55	75	37	11	12,5	–	M 55x2	–	–	–	0,28	▶ H 211	KM 11	MB 11	HMV 11E
	55	75	45	11	12,5	–	M 55x2	–	–	–	0,32	▶ H 311	KM 11	MB 11	HMV 11 E
	55	75	45	14	–	–	M 55x2	–	–	–	0,34	▶ H 311 E	KMFE 11	–	HMV 11 E
55	60	80	38	11	13	–	M 60x2	–	–	–	0,31	▶ H 212	KM 12	MB 12	HMV 12E
	60	80	47	11	13	–	M 60x2	–	–	–	0,36	▶ H 312	KM 12	MB 12	HMV 12 E
	60	80	47	14	–	–	M 60x2	–	–	–	0,4	▶ H 312 E	KMFE 12	–	HMV 12 E
60	65	85	40	12	13,5	–	M 65x2	–	–	–	0,36	▶ H 213	KM 13	MB 13	HMV 13E
	65	85	50	12	13,5	–	M 65x2	–	–	–	0,42	▶ H 313	KM 13	MB 13	HMV 13 E
	65	85	50	15	–	–	M 65x2	–	–	–	0,43	▶ H 313 E	KMFE 13	–	HMV 13 E
	65	85	65	15	–	–	M 65x2	–	–	–	0,53	▶ H 2313 E	KMFE 13	–	HMV 13 E
	70	92	52	12	13,5	–	M 70x2	–	–	–	0,67	▶ H 314	KM 14	MB 14	HMV 14 E
	70	92	52	15	–	–	M 70x2	–	–	–	0,67	▶ H 314 E	KMFE 14	–	HMV 14 E
65	75	98	43	13	14,5	–	M 75x2	–	–	–	0,66	▶ H 215	KM 15	MB 15	HMV 15E
	75	98	55	13	14,5	–	M 75x2	–	–	–	0,78	▶ H 315	KM 15	MB 15	HMV 15 E
	75	98	55	16	–	–	M 75x2	–	–	–	0,82	▶ H 315 E	KMFE 15	–	HMV 15 E

▶ Popular item

Principal dimensions											Mass	Designations		Included products		Associated hydraulic nut
d <sub>1</sub>	d	d <sub>3</sub>	B <sub>1</sub>	B	B <sub>4</sub>	B <sub>5</sub>	G	G <sub>2</sub>	G <sub>3</sub>	A		Adapter sleeve assembly	lock nut	locking device		
mm											kg	–				
<b>70</b>	80	105	46	15	17	–	M 80x2	–	–	–	0,81	▶ <b>H 216</b>	KM 16	MB 16	HMV 16E	
	80	105	59	15	17	–	M 80x2	–	–	–	0,95	▶ <b>H 316</b>	KM 16	MB 16	HMV 16 E	
	80	105	59	18	–	–	M 80x2	–	–	–	1	▶ <b>H 316 E</b>	KMFE 16	–	HMV 16 E	
<b>75</b>	85	110	50	16	18	–	M 85x2	–	–	–	0,94	▶ <b>H 217</b>	KM 17	MB 17	HMV 17E	
	85	110	63	16	18	–	M 85x2	–	–	–	1,1	▶ <b>H 317</b>	KM 17	MB 17	HMV 17 E	
	85	110	63	19	–	–	M 85x2	–	–	–	1,15	▶ <b>H 317 E</b>	KMFE 17	–	HMV 17 E	
<b>80</b>	90	120	52	16	18	–	M 90x2	–	–	–	1,1	▶ <b>H 218</b>	KM 18	MB 18	HMV 18E	
	90	120	65	16	18	–	M 90x2	–	–	–	1,3	▶ <b>H 318</b>	KM 18	MB 18	HMV 18 E	
	90	120	65	19	–	–	M 90x2	–	–	–	1,45	▶ <b>H 318 E</b>	KMFE 18	–	HMV 18 E	
<b>85</b>	95	125	55	17	19	–	M 95x2	–	–	–	1,25	▶ <b>H 219</b>	KM 19	MB 19	HMV 19E	
	95	125	68	17	19	–	M 95x2	–	–	–	1,4	▶ <b>H 319</b>	KM 19	MB 19	HMV 19 E	
	95	125	68	20	–	–	M 95x2	–	–	–	1,45	▶ <b>H 319 E</b>	KMFE 19	–	HMV 19 E	
<b>90</b>	100	130	58	18	20	–	M 100x2	–	–	–	1,4	▶ <b>H 220</b>	KM 20	MB 20	HMV 20E	
	100	130	71	18	20	–	M 100x2	–	–	–	1,6	▶ <b>H 320</b>	KM 20	MB 20	HMV 20 E	
	100	130	71	21	–	–	M 100x2	–	–	–	1,7	▶ <b>H 320 E</b>	KMFE 20	–	HMV 20 E	
	100	130	76	18	20	–	M 100x2	–	–	–	1,8	▶ <b>H 3120</b>	KM 20	MB 20	HMV 20 E	
	100	130	76	21	–	–	M 100x2	–	–	–	1,8	▶ <b>H 3120 E</b>	KMFE 20	–	HMV 20 E	
	100	130	97	21	–	–	M 100x2	–	–	–	2	▶ <b>H 2320 E</b>	KMFE 20	–	HMV 20 E	
<b>100</b>	110	145	63	19	21	–	M 110x2	–	–	–	1,8	▶ <b>H 222</b>	KM 22	MB 22	HMV 22E	
	110	145	77	19	21	–	M 110x2	–	–	–	2,05	▶ <b>H 322</b>	KM 22	MB 22	HMV 22 E	
	110	145	77	21,5	–	–	M 110x2	–	–	–	2,1	▶ <b>H 322 E</b>	KMFE 22	–	HMV 22 E	
	110	145	81	19	21	–	M 110x2	–	–	–	2,1	▶ <b>H 3122</b>	KM 22	MB 22	HMV 22 E	
	110	145	81	21,5	–	–	M 110x2	–	–	–	2,15	▶ <b>H 3122 E</b>	KMFE 22	–	HMV 22 E	
	110	145	105	21,5	–	–	M 110x2	–	–	–	2,75	▶ <b>H 2322 E</b>	KMFE 22	–	HMV 22 E	
<b>110</b>	120	155	72	26	–	–	M 120x2	–	–	–	1,85	▶ <b>H 3024 E</b>	KMFE 24	–	HMV 24 E	
	120	155	88	20	22	–	M 120x2	–	–	–	2,5	▶ <b>H 3124</b>	KM 24	MB 24	HMV 24 E	
	120	155	112	26	–	–	M 120x2	–	–	–	3,1	▶ <b>H 2324 E</b>	KMFE 24	–	HMV 24 E	
<b>115</b>	130	165	80	28	–	–	M 130x2	–	–	–	2,9	▶ <b>H 3026 E</b>	KMFE 26	–	HMV 26 E	
	130	165	92	21	23	–	M 130x2	–	–	–	3,45	▶ <b>H 3126</b>	KM 26	MB 26	HMV 26 E	
<b>125</b>	140	180	82	28	–	–	M 140x2	–	–	–	3,05	▶ <b>H 3028 E</b>	KMFE 28	–	HMV 28 E	
	140	180	97	22	24	–	M 140x2	–	–	–	4,1	▶ <b>H 3128</b>	KM 28	MB 28	HMV 28 E	
<b>135</b>	150	195	87	30	–	–	M 150x2	–	–	–	3,75	▶ <b>H 3030 E</b>	KMFE 30	–	HMV 30 E	
	150	195	111	24	26	–	M 150x2	–	–	–	5,25	▶ <b>H 3130</b>	KM 30	MB 30	HMV 30 E	
	150	195	111	30	–	–	M 150x2	–	–	–	4,7	▶ <b>H 3130 E</b>	KMFE 30	–	HMV 30 E	
<b>140</b>	160	210	93	32	–	–	M 160x3	–	–	–	5,1	▶ <b>H 3032 E</b>	KMFE 32	–	HMV 32 E	
	160	210	119	25	28	–	M 160x3	–	–	–	7,25	▶ <b>H 3132</b>	KM 32	MB 32	HMV 32 E	
	160	210	119	32	–	–	M 160x3	–	–	–	7,35	▶ <b>H 3132 E</b>	KMFE 32	–	HMV 32 E	
<b>150</b>	170	220	101	33	–	–	M 170x3	–	–	–	5,9	▶ <b>H 3034 E</b>	KMFE 34	–	HMV 34 E	
	170	220	122	26	29	–	M 170x3	–	–	–	8,1	▶ <b>H 3134</b>	KM 34	MB 34	HMV 34 E	
	170	220	122	33	–	–	M 170x3	–	–	–	8,1	▶ <b>H 3134 E</b>	KMFE 34	–	HMV 34 E	
<b>160</b>	180	230	109	34	–	–	M 180x3	–	–	–	6,7	▶ <b>H 3036 E</b>	KMFE 36	–	HMV 36 E	
	180	230	131	27	29,5	–	M 180x3	–	–	–	9,15	▶ <b>H 3136</b>	KM 36	MB 36	HMV 36 E	
<b>170</b>	190	240	141	28	30,5	–	M 190x3	–	–	–	10,5	▶ <b>H 3138</b>	KM 38	MB 38	HMV 38 E	
<b>180</b>	200	250	150	29	31,5	–	M 200x3	–	–	–	12	▶ <b>H 3140</b>	KM 40	MB 40	HMV 40 E	

▶ Popular item



## 23.1 Adapter sleeves for metric shafts

$d_1$  200 – 500 mm

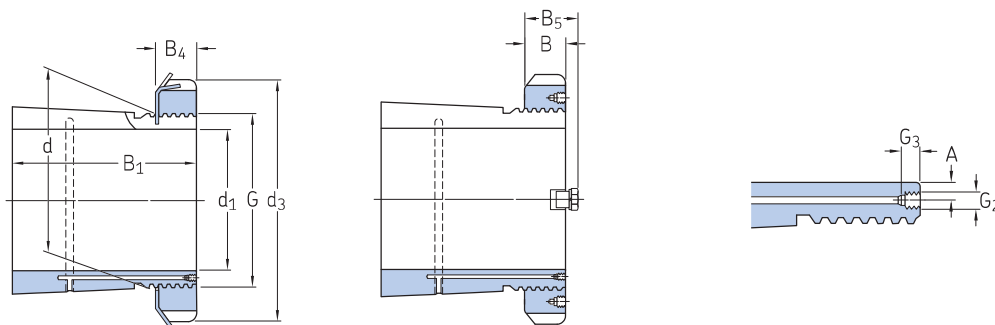

Principal dimensions											Mass	Designations			
$d_1$	d	$d_3$	$B_1$	B	$B_4$	$B_5$	G	$G_2$	$G_3$	A		Adapter sleeve assembly	Included products lock nut	locking device	Associated hydraulic nut
mm											kg	–			
200	220	260	126	30	–	41	Tr 220x4	M 6	9	6,5	9,9	▶ OH 3044 H	HM 3044	MS 3044	HMV 44E
	220	280	161	32	35	–	Tr 220x4	M 6	9	4,2	15	▶ OH 3144 H	HM 44 T	MB 44	HMV 44E
220	240	290	133	34	–	46	Tr 240x4	M 6	9	4,2	12	▶ OH 3048 H	HM 3048	MS 3052-48	HMV 48E
	240	300	172	34	37	–	Tr 240x4	M 6	9	4,2	16,5	▶ OH 3148 H	HM 48 T	MB 48	HMV 48E
240	260	310	145	34	–	46	Tr 260x4	M 6	9	4,2	13,5	▶ OH 3052 H	HM 3052	MS 3052-48	HMV 52E
	260	330	190	36	39	–	Tr 260x4	M 6	9	4,2	21	▶ OH 3152 H	HM 52 T	MB 52	HMV 52E
260	280	330	152	38	–	50	Tr 280x4	M 6	9	6,5	16	▶ OH 3056 H	HM 3056	MS 3056	HMV 56E
	280	350	195	38	41	–	Tr 280x4	M 6	9	4,2	23	▶ OH 3156 H	HM 56 T	MB 56	HMV 56E
280	300	360	168	42	–	54	Tr 300x4	M 6	9	6,5	20,5	▶ OH 3060 H	HM 3060	MS 3060	HMV 60E
	300	380	208	40	–	53	Tr 300x4	M 6	9	4,2	29	▶ OH 3160 H	HM 3160	MS 3160	HMV 60E
	300	380	240	40	–	53	Tr 300x4	M 6	9	4,2	32	▶ OH 3260 H	HM 3160	MS 3160	HMV 60E
300	320	380	171	42	–	55	Tr 320x5	M 6	9	6,5	22	▶ OH 3064 H	HM 3064	MS 3068-64	HMV 64E
	320	400	226	42	–	56	Tr 320x5	M 6	9	4	32	▶ OH 3164 H	HM 3164	MS 3164	HMV 64E
	320	400	258	42	–	56	Tr 320x5	M 6	9	4	35	OH 3264 H	HM 3164	MS 3164	HMV 64E
320	340	400	187	45	–	58	Tr 340x5	M 6	9	6,5	27	▶ OH 3068 H	HM 3068	MS 3068-64	HMV 68E
	340	440	254	55	–	72	Tr 340x5	M 6	9	4	50	▶ OH 3168 H	HM 3168	MS 3172-68	HMV 68E
	340	440	288	55	–	72	Tr 340x5	M 6	9	4	51,5	▶ OH 3268 H	HM 3168	MS 3172-68	HMV 68E
340	360	420	188	45	–	58	Tr 360x5	M 6	9	6,5	29	▶ OH 3072 H	HM 3072	MS 3072	HMV 72E
	360	460	259	58	–	75	Tr 360x5	M 6	9	4	56	▶ OH 3172 H	HM 3172	MS 3172-68	HMV 72E
	360	460	299	58	–	75	Tr 360x5	M 6	9	4	60,5	OH 3272 H	HM 3172	MS 3172-68	HMV 72E
360	380	450	193	48	–	62	Tr 380x5	M 6	9	6,5	35,5	▶ OH 3076 H	HM 3076	MS 3080-76	HMV 76E
	380	490	264	60	–	77	Tr 380x5	M 6	9	4	61,5	▶ OH 3176 H	HM 3176	MS 3176	HMV 76E
	380	490	310	60	–	77	Tr 380x5	M 6	9	4	69,5	OH 3276 H	HM 3176	MS 3176	HMV 76E
380	400	470	210	52	–	66	Tr 400x5	M 6	9	6,5	40	▶ OH 3080 H	HM 3080	MS 3080-76	HMV 80E
	400	520	272	62	–	82	Tr 400x5	M 6	9	4	73	▶ OH 3180 H	HM 3180	MS 3184-80	HMV 80E
	400	520	328	62	–	82	Tr 400x5	M 6	9	4	87	OH 3280 H	HM 3180	MS 3184-80	HMV 80E
400	420	490	212	52	–	66	Tr 420x5	M 6	9	6,5	47	▶ OH 3084 H	HM 3084	MS 3084	HMV 84E
	420	540	304	70	–	90	Tr 420x5	M 6	9	4	80	▶ OH 3184 H	HM 3184	MS 3184-80	HMV 84E
	420	540	352	70	–	90	Tr 420x5	M 6	9	4	96	OH 3284 H	HM 3184	MS 3184-80	HMV 84E
410	440	520	228	60	–	77	Tr 440x5	M 8	12	6,5	65	▶ OH 3088 H	HM 3088	MS 3092-88	HMV 88E
	440	560	307	70	–	90	Tr 440x5	M 8	12	6,5	95	▶ OH 3188 H	HM 3188	MS 3192-88	HMV 88E
	440	560	361	70	–	90	Tr 440x5	M 8	12	6,5	117	OH 3288 H	HM 3188	MS 3192-88	HMV 88E
430	460	540	234	60	–	77	Tr 460x5	M 8	12	6,5	71	▶ OH 3092 H	HM 3092	MS 3092-88	HMV 92E
	460	580	326	75	–	95	Tr 460x5	M 8	12	6,5	119	▶ OH 3192 H	HM 3192	MS 3192-88	HMV 92E

▶ Popular item

Principal dimensions											Mass	Designations			Associated hydraulic nut
d <sub>1</sub>	d	d <sub>3</sub>	B <sub>1</sub>	B	B <sub>4</sub>	B <sub>5</sub>	G	G <sub>2</sub>	G <sub>3</sub>	A		Adapter sleeve assembly	Included products lock nut	locking device	
mm											kg	–			
<b>450</b>	480	560	237	60	–	77	Tr 480x5	M 8	12	6,5	75	<b>OH 3096 H</b>	HM 3096	MS 30/500-96	HMV 96E
	480	620	335	75	–	95	Tr 480x5	M 8	12	6,5	135	<b>OH 3196 H</b>	HM 3196	MS 3196	HMV 96E
<b>500</b>	530	630	265	68	–	90	Tr 530x6	M 8	12	6,5	105	<b>OH 30/530 H</b>	HM 30/530	MS 30/600-530	HMV 106E





## 23.2 Adapter sleeves with inch dimensions

$d_1$  3/4 – 3 1/4 in.  
19,05 – 82,55 mm

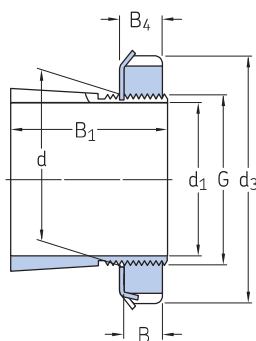

Principal dimensions							Thread	Mass	Designations	Included products		Associated	
$d_1$	d	$d_3$ max.	$B_1$	B	$B_4$	$B_5$	G	Threads per inch	Adapter sleeve assembly	lock nut	locking device	hydraulic nut	
in./mm	mm	in.					in.	–	–				
3/4 19,05	25	1,568	1,259	0,416	0,456	–	0,969	32	0,11	▶ SNW 5x3/4	N 05	W 05	–
15/16 23,813	30	1,755	1,343	0,416	0,456	–	1,173	18	0,14	▶ SNW 6x15/16	N 06	W 06	–
1 25,4	30	1,755	1,343	0,416	0,456	–	1,173	18	0,13	▶ SNW 6x1	N 06	W 06	–
1 1/8 28,575	35	2,068	1,449	0,448	0,488	–	1,376	18	0,16	▶ SNW 7x1.1/8	N 07	W 07	–
1 3/16 30,163	35	2,068	1,449	0,448	0,488	–	1,376	18	0,16	▶ SNW 7x1.3/16	N 07	W 07	–
1 1/4 31,75	35	2,068	1,449	0,448	0,488	–	1,376	18	0,16	SNW 7x1.1/4	N 07	W 07	–
	40	2,255	1,494	0,448	0,496	–	0,496	18	0,19	▶ SNW 8x1.1/4	N 08	W 08	–
1 5/16 33,338	40	2,255	1,494	0,448	0,496	–	1,563	18	0,19	SNW 8x1.5/16	N 08	W 08	–
	45	2,536	1,574	0,448	0,496	–	1,767	18	0,28	▶ SNW 9x1.5/16	N 09	W 09	–
1 3/8 34,925	40	2,255	1,494	0,448	0,496	–	1,563	18	0,19	▶ SNW 8x1.3/8	N 08	W 08	–
	45	2,536	1,574	0,448	0,496	–	1,767	18	0,28	▶ SNW 9x1.3/8	N 09	W 09	–
	45	2,536	2,123	0,448	0,496	–	1,767	18	0,32	SNW 109x1.3/8	N 09	W 09	–
1 7/16 36,513	45	2,536	1,574	0,448	0,496	–	1,767	18	0,28	▶ SNW 9x1.7/16	N 09	W 09	–
	45	2,536	1,574	0,448	0,496	–	1,767	18	0,32	▶ SNW 109x1.7/16	N 09	W 09	–
1 1/2 38,1	45	2,536	1,574	0,448	0,496	–	1,767	18	0,28	SNW 9x1.1/2	N 09	W 09	–
	45	2,536	2,123	0,448	0,496	–	1,767	18	0,32	▶ SNW 109x1.1/2	N 09	W 09	–
	50	2,536	1,755	0,448	0,558	–	1,967	18	0,33	SNW 10x1.1/2	N 09	W 10	HMVC 10E
1 5/8 41,275	50	2,693	1,755	0,51	0,558	–	1,967	18	0,33	▶ SNW 10x1.5/8	N 10	W 10	HMVC 10E
	55	2,693	2,384	0,51	0,558	–	1,967	18	0,39	SNW 110x1.5/8	N 10	W 10	HMVC 10E
1 11/16 42,863	50	2,693	1,755	0,51	0,558	–	1,967	18	0,33	▶ SNW 10x1.11/16	N 10	W 10	HMVC 10E
	50	2,693	2,384	0,51	0,558	–	1,967	18	0,39	▶ SNW 110x1.11/16	N 10	W 10	HMVC 10E
1 3/4 44,45	50	2,693	1,755	0,51	0,558	–	1,967	18	0,33	SNW 10x1.3/4	N 10	W 10	HMVC 10E
	55	2,693	2,384	0,51	0,558	–	1,967	18	0,39	▶ SNW 110x1.3/4	N 10	W 10	HMVC 10E
	55	2,974	1,835	0,51	0,563	–	2,157	18	0,36	▶ SNW 11x1.3/4	N 11	W 11	HMVC 11E
1 13/16 46,038	55	2,974	1,835	0,51	0,563	–	2,157	18	0,36	▶ SNW 11x1.13/16	N 11	W 11	HMVC 11E

▶ Popular item

Principal dimensions							Thread	Mass	Designations	Included products		Associated	
d <sub>1</sub>	d	d <sub>3</sub> max.	B <sub>1</sub>	B	B <sub>4</sub>	B <sub>5</sub>	G	Threads per inch	Adapter sleeve assembly	lock nut	locking device	hydraulic nut	
in./mm	mm	in.					in.	–	kg	–			
<b>1 7/8</b> 47,625	55 55	2,974 2,974	1,835 2,506	0,51 0,51	0,563 0,563	– –	2,157 2,157	18 18	0,36 0,43	▶ <b>SNW 11x1.7/8</b> <b>SNW 111x1.7/8</b>	N 11 N 11	W 11 W 11	HMVC 11E HMVC 11E
<b>1 15/16</b> 49,213	55 55	2,974 2,974	1,835 2,506	0,51 0,51	0,563 0,563	– –	2,157 2,157	18 18	0,36 0,43	▶ <b>SNW 11x1.15/16</b> ▶ <b>SNW 111x1.15/16</b>	N 11 N 11	W 11 W 11	HMVC 11E HMVC 11E
<b>2</b> 50,8	55 55 65	2,974 2,974 3,38	1,835 2,506 2,09	0,51 0,51 0,573	0,563 0,563 0,573	– – –	2,157 2,157 2,548	18 18 18	0,36 0,43 0,64	▶ <b>SNW 11x2</b> <b>SNW 111x2</b> ▶ <b>SNW 13x2</b>	N 11 N 11 N 13	W 11 W 11 W 13	HMVC 11E HMVC 11E HMVC 13E
<b>2 1/16</b> 52,388	60	3,161	2,649	0,541	0,594	–	2,36	18	0,73	▶ <b>SNW 112x2.1/16</b>	N 12	W 12	HMVC 12E
<b>2 1/8</b> 53,975	65 65	3,38 3,38	2,09 2,09	0,573 0,573	0,626 0,626	– –	2,548 2,548	18 18	0,64 0,79	<b>SNW 13x2.1/8</b> <b>SNW 113x2.1/8</b>	N 13 N 13	W 13 W 13	HMVC 13E HMVC 13E
<b>2 3/16</b> 55,563	65 65	3,38 3,38	2,09 2,761	0,573 0,573	0,626 0,626	– –	2,548 2,548	18 18	0,64 0,79	▶ <b>SNW 13x2.3/16</b> ▶ <b>SNW 113x2.3/16</b>	N 13 N 13	W 13 W 13	HMVC 13E HMVC 13E
<b>2 1/4</b> 57,15	65 65	3,38 3,38	2,09 2,761	0,573 0,573	0,626 0,626	– –	2,548 2,548	18 18	0,64 0,79	▶ <b>SNW 13x2.1/4</b> ▶ <b>SNW 113x2.1/4</b>	N 13 N 13	W 13 W 13	HMVC 13E HMVC 13E
<b>2 5/16</b> 58,738	65	3,38	2,09	0,573	0,626	–	2,548	18	0,64	▶ <b>SNW 13x2.5/16</b>	N 13	W 13	HMVC 13E
<b>2 3/8</b> 60,325	75 75	3,88 3,88	2,286 3,074	0,604 0,604	0,666 0,666	– –	2,933 2,933	12 12	1 1,35	▶ <b>SNW 15x2.3/8</b> <b>SNW 115x2.3/8</b>	AN 15 AN 15	W 15 W 15	HMVC 15E HMVC 15E
<b>2 7/16</b> 61,913	75 75	3,88 3,88	2,286 3,074	0,604 0,604	0,666 0,666	– –	2,933 2,933	12 12	1 1,35	▶ <b>SNW 15x2.7/16</b> ▶ <b>SNW 115x2.7/16</b>	AN 15 AN 15	W 15 W 15	HMVC 15E HMVC 15E
<b>2 1/2</b> 63,5	75 75	3,88 3,88	2,286 3,074	0,604 0,604	0,666 0,666	– –	2,933 2,933	12 12	1 1,35	<b>SNW 15x2.1/2</b> <b>SNW 115x2.1/2</b>	AN 15 AN 15	W 15 W 15	HMVC 15E HMVC 15E
<b>2 5/8</b> 66,675	80 80	4,161 4,161	2,366 3,194	0,604 0,604	0,666 0,666	– –	3,137 3,137	12 12	1,1 1,45	<b>SNW 16x2.5/8</b> <b>SNW 116x2.5/8</b>	AN 16 AN 16	W 16 W 16	HMVC 16E HMVC 16E
<b>2 11/16</b> 68,263	80 80	4,161 4,161	2,366 3,194	0,604 0,604	0,666 0,666	– –	3,137 3,137	12 12	1,1 1,45	▶ <b>SNW 16x2.11/16</b> ▶ <b>SNW 116x2.11/16</b>	AN 16 AN 16	W 16 W 16	HMVC 16E HMVC 16E
<b>2 3/4</b> 69,85	80 80	4,161 4,161	2,366 3,194	0,604 0,604	0,666 0,666	– –	3,137 3,137	12 12	1,1 1,45	▶ <b>SNW 16x2.3/4</b> <b>SNW 116x2.3/4</b>	AN 16 AN 16	W 16 W 16	HMVC 16E HMVC 16E
<b>2 13/16</b> 71,438	85 85	4,411 4,411	2,476 3,302	0,635 0,635	0,697 0,697	– –	3,34 3,34	12 12	1,3 1,55	<b>SNW 17x2.13/16</b> <b>SNW 117x2.13/16</b>	AN 17 AN 17	W 17 W 17	HMVC 17E HMVC 17E
<b>2 7/8</b> 73,025	85 85	4,411 4,411	2,476 3,302	0,635 0,635	0,697 0,697	– –	3,34 3,34	12 12	1,3 1,55	<b>SNW 17x2.7/8</b> <b>SNW 117x2.7/8</b>	AN 17 AN 17	W 17 W 17	HMVC 17E HMVC 17E
<b>2 15/16</b> 74,613	85 85	4,411 4,411	2,476 3,302	0,635 0,635	0,697 0,697	– –	3,34 3,34	12 12	1,3 1,55	▶ <b>SNW 17x2.15/16</b> ▶ <b>SNW 117x2.15/16</b>	AN 17 AN 17	W 17 W 17	HMVC 17E HMVC 17E
<b>3</b> 76,2	85 85	4,411 4,411	2,476 3,302	0,635 0,635	0,697 0,697	– –	3,34 3,34	12 12	1,3 1,55	▶ <b>SNW 17x3</b> ▶ <b>SNW 117x3</b>	AN 17 AN 17	W 17 W 17	HMVC 17E HMVC 17E
<b>3 1/16</b> 77,788	90 90	4,661 4,661	2,636 3,543	0,698 0,698	0,782 0,782	– –	3,527 3,527	12 12	1,4 1,8	▶ <b>SNW 18x3.1/16</b> <b>SNW 118x3.1/16</b>	AN 18 AN 18	W 18 W 18	HMVC 18E HMVC 18E
<b>3 1/8</b> 79,375	90 90	4,661 4,661	2,636 3,543	0,698 0,698	0,782 0,782	– –	3,527 3,527	12 12	1,4 1,8	<b>SNW 18x3.1/8</b> <b>SNW 118x3.1/8</b>	AN 18 AN 18	W 18 W 18	HMVC 18E HMVC 18E
<b>3 3/16</b> 80,963	90 90	4,661 4,661	2,636 3,543	0,698 0,698	0,782 0,782	– –	3,527 3,527	12 12	1,4 1,8	<b>SNW 18x3.3/16</b> ▶ <b>SNW 118x3.3/16</b>	AN 18 AN 18	W 18 W 18	HMVC 18E HMVC 18E
<b>3 1/4</b> 82,55	90 90	4,661 4,661	2,636 3,543	0,698 0,698	0,782 0,782	– –	3,527 3,527	12 12	1,4 1,8	<b>SNW 18x3.1/4</b> <b>SNW 118x3.1/4</b>	AN 18 AN 18	W 18 W 18	HMVC 18E HMVC 18E

▶ Popular item



## 23.2 Adapter sleeves with inch dimensions

$d_1$  3 5/16 – 5 1/4 in.  
84,138 – 133,35 mm

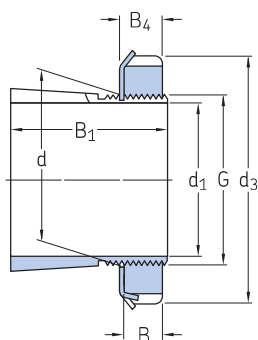

Principal dimensions							Thread	Mass	Designations	Included products		Associated
$d_1$	$d$	$d_3$ max.	$B_1$	$B$	$B_4$	$B_5$	$G$	Threads per inch	Adapter sleeve assembly	lock nut	locking device	hydraulic nut
in./mm	mm	in.					in.	–	–			
<b>3 5/16</b> 84,138	95	4,943	2,75	0,729	0,813	–	3,73	12	▶ <b>SNW 19x3.5/16</b>	AN 19	W 19	HMVC 19E
	95	4,943	3,692	0,729	0,813	–	3,73	12	▶ <b>SNW 119x3.5/16</b>	AN 19	W 19	HMVC 19E
	100	5,193	2,859	0,76	0,844	–	3,918	12	<b>SNW 20x3.5/16</b>	AN 20	W 20	HMVC 20E
	100	3,918	3,961	0,76	0,844	–	3,918	12	<b>SNW 120x3.5/16</b>	AN 20	W 20	HMVC 20E
<b>3 3/8</b> 85,725	100	5,193	2,859	0,76	0,844	–	3,918	12	<b>SNW 20x3.3/8</b>	AN 20	W 20	HMVC 20E
	100	5,193	3,961	0,76	0,844	–	3,918	12	<b>SNW 120x3.3/8</b>	AN 20	W 20	HMVC 20E
<b>3 7/16</b> 87,313	100	5,193	2,859	0,76	0,844	–	3,918	12	▶ <b>SNW 20x3.7/16</b>	AN 20	W 20	HMVC 20E
	100	5,193	3,961	0,76	0,844	–	3,918	12	▶ <b>SNW 120x3.7/16</b>	AN 20	W 20	HMVC 20E
<b>3 1/2</b> 88,9	100	5,193	2,859	0,76	0,844	–	3,918	12	▶ <b>SNW 20x3.1/2</b>	AN 20	W 20	HMVC 20E
	100	5,193	3,961	0,76	0,844	–	3,918	12	▶ <b>SNW 120x3.1/2</b>	AN 20	W 20	HMVC 20E
<b>3 11/16</b> 93,663	105	5,443	2,977	0,76	0,844	–	4,122	12	▶ <b>SNW 21x3.11/16</b>	AN 21	W 21	HMVC 21E
	105	5,443	4,157	0,76	0,844	–	4,122	12	▶ <b>SNW 121x3.11/16</b>	AN 21	W 21	HMVC 21E
	110	5,724	3,196	0,791	0,906	–	4,325	12	<b>SNW 22x3.11/16</b>	AN 22	W 22	HMVC 22E
	110	5,724	4,338	0,791	3,693	–	4,325	6	<b>SNW 122x3.11/16</b>	AN 22	W 22	HMVC 22E
<b>3 3/4</b> 95,25	110	5,724	4,338	0,791	0,906	–	4,325	12	<b>SNW 122x3.3/4</b>	AN 22	W 22	HMVC 22E
<b>3 13/16</b> 96,838	110	5,724	3,196	0,791	0,906	–	4,325	12	<b>SNW 22x3.13/16</b>	AN 22	W 22	HMVC 22E
	110	5,724	4,338	0,791	0,906	–	4,325	12	<b>SNW 122x3.13/16</b>	AN 22	W 22	HMVC 22E
<b>3 7/8</b> 98,425	110	5,724	3,196	0,791	0,906	–	4,325	12	<b>SNW 22x3.7/8</b>	AN 22	W 22	HMVC 22E
	4,338	5,724	4,338	0,791	0,906	–	4,325	12	<b>SNW 122x3.7/8</b>	AN 22	W 22	HMVC 22E
<b>3 15/16</b> 100,013	110	5,724	3,196	0,791	0,906	–	4,325	12	▶ <b>SNW 22x3.15/16</b>	AN 22	W 22	HMVC 22E
	110	5,724	4,338	0,791	0,906	–	4,325	12	▶ <b>SNW 122x3.15/16</b>	AN 22	W 22	HMVC 22E
<b>4</b> 101,6	110	5,724	3,196	0,791	0,906	–	4,325	12	▶ <b>SNW 22x4</b>	AN 22	W 22	HMVC 22E
	110	5,724	4,338	0,791	0,906	–	4,325	12	<b>SNW 122x4</b>	AN 22	W 22	HMVC 22E
	120	6,13	2,937	0,823	0,938	–	4,716	12	<b>SNW 3024x4</b>	AN 24	W 24	HMVC 24E
	120	6,13	3,456	0,823	0,938	–	4,716	12	<b>SNW 24x4</b>	AN 24	W 24	HMVC 24E
	120	6,13	4,638	0,823	0,938	–	4,716	12	<b>SNW 124x4</b>	AN 24	W 24	HMVC 24E
<b>4 1/16</b> 103,188	120	5,693	2,937	0,823	0,938	–	4,716	12	<b>SNW 3024x4.1/16</b>	N 024	W 024	HMVC 24E
	120	6,13	3,456	0,823	0,938	–	4,716	12	<b>SNW 24x4.1/16</b>	AN 24	W 24	HMVC 24E
	120	6,13	4,638	0,823	0,938	–	4,716	12	<b>SNW 124x4.1/16</b>	AN 24	W 24	HMVC 24E
<b>4 1/8</b> 104,775	120	5,693	2,937	0,823	0,938	–	4,716	12	<b>SNW 3024x4.1/8</b>	N 024	W 024	HMVC 24E
	120	6,13	3,456	0,823	0,938	–	4,716	12	<b>SNW 24x4.1/8</b>	AN 24	W 24	HMVC 24E
	120	6,13	4,638	0,823	0,938	–	4,716	12	<b>SNW 124x4.1/8</b>	AN 24	W 24	HMVC 24E

▶ Popular item

Principal dimensions							Thread	Mass	Designations	Included products		Associated	
d <sub>1</sub>	d	d <sub>3</sub> max.	B <sub>1</sub>	B	B <sub>4</sub>	B <sub>5</sub>	G	Threads per inch	Adapter sleeve assembly	lock nut	locking device	hydraulic nut	
in./mm	mm	in.					in.	–	kg	–			
<b>4 3/16</b> 106,363	120	5,693	2,937	0,823	0,938	–	4,716	12	2,8	▶ <b>SNW 3024x4.3/16</b> <b>SNW 3124x4.3/16</b>	N 024	W 024	HMVC 24E
	120	5,693	3,456	0,823	0,938	–	4,716	12	2,65		N 024	W 024	HMVC 24E
	120	6,13	3,456	0,823	0,938	–	4,716	12	3	▶ <b>SNW 24x4.3/16</b>	AN 24	W 24	HMVC 24E
	120	6,13	4,638	0,823	0,938	–	4,716	12	3,55	▶ <b>SNW 124x4.3/16</b>	AN 24	W 24	HMVC 24E
<b>4 1/4</b> 107,95	120	5,693	2,937	0,823	0,938	–	4,716	12	2,8	<b>SNW 3024x4.1/4</b> ▶ <b>SNW 3124x4.1/4</b>	N 024	W 024	HMVC 24E
	120	5,693	3,456	0,823	0,938	–	4,716	12	2,65		N 024	W 024	HMVC 24E
	120	6,13	3,456	0,823	0,938	–	4,716	12	3	▶ <b>SNW 24x4.1/4</b>	AN 24	W 24	HMVC 24E
	120	6,13	4,638	0,823	0,938	–	4,716	12	3,55	<b>SNW 124x4.1/4</b>	AN 24	W 24	HMVC 24E
<b>4 5/16</b> 109,538	130	6,13	3,227	0,885	1	–	5,106	12	3,4	<b>SNW 3026x4.5/16</b> <b>SNW 26x4.5/16</b> <b>SNW 126x4.5/16</b>	N 026	W 026	HMVC 26E
	130	6,755	3,752	0,885	1	–	5,106	12	4,4		AN 26	W 26	HMVC 26E
	130	6,755	4,972	0,885	1	–	5,106	12	5,65		AN 26	W 26	HMVC 26E
<b>4 3/8</b> 111,125	130	6,13	3,227	0,885	1	–	5,106	12	3,4	<b>SNW 3026x4.3/8</b> <b>SNW 26x4.3/8</b> <b>SNW 126x4.3/8</b>	N 026	W 026	HMVC 26E
	130	6,755	3,752	0,885	1	–	5,106	12	4,4		AN 26	W 26	HMVC 26E
	130	6,755	4,972	0,885	1	–	5,106	12	5,65		AN 26	W 26	HMVC 26E
<b>4 7/16</b> 112,713	130	6,13	3,227	0,885	1	–	5,106	12	3,4	▶ <b>SNW 3026x4.7/16</b> ▶ <b>SNW 3126x4.7/16</b>	N 026	W 026	HMVC 26E
	130	6,13	3,752	0,885	1	–	5,106	12	3,8		N 026	W 026	HMVC 26E
	130	6,755	3,752	0,885	1	–	5,106	12	4,4		AN 26	W 26	HMVC 26E
	130	6,755	4,972	0,885	1	–	5,106	12	5,65	▶ <b>SNW 126x4.7/16</b>	AN 26	W 26	HMVC 26E
	140	7,099	5,313	0,948	1	–	5,497	12	5,9	<b>SNW 128x4.7/16</b>	AN 28	W 28	HMVC 28E
<b>4 1/2</b> 114,3	130	6,13	3,227	0,885	1	–	5,106	12	3,4	▶ <b>SNW 3026x4.1/2</b> ▶ <b>SNW 3126x4.1/2</b> ▶ <b>SNW 26x4.1/2</b>	N 026	W 026	HMVC 26E
	130	6,13	3,752	0,885	1	–	5,106	12	3,8		N 026	W 026	HMVC 26E
	130	6,755	3,752	0,885	1	–	5,106	12	4,4		AN 26	W 26	HMVC 26E
	130	6,755	4,972	0,885	1	–	5,106	12	5,65	<b>SNW 126x4.1/2</b>	AN 26	W 26	HMVC 26E
<b>4 13/16</b> 122,238	140	6,505	3,33	0,948	1,063	–	5,497	12	3,8	<b>SNW 3028x4.13/16</b> <b>SNW 28x4.13/16</b> <b>SNW 128x4.13/16</b>	N 028	W 028	HMVC 28E
	140	7,099	3,971	0,948	1,063	–	5,497	12	4,75		AN 28	W 28	HMVC 28E
	140	7,099	5,313	0,948	1,063	–	5,497	12	5,9		AN 28	W 28	HMVC 28E
<b>4 7/8</b> 123,825	140	6,505	3,33	0,948	1,063	–	5,497	12	3,8	<b>SNW 3028x4.7/8</b> <b>SNW 28x4.7/8</b> <b>SNW 128x4.7/8</b>	N 028	W 028	HMVC 28E
	140	7,099	3,971	0,948	1,063	–	5,497	12	4,75		AN 28	W 28	HMVC 28E
	140	7,099	5,313	0,948	0,906	–	5,497	12	5,9		AN 28	W 28	HMVC 28E
<b>4 15/16</b> 125,413	140	6,505	3,33	0,948	1,063	–	5,888	12	3,8	▶ <b>SNW 3028x4.15/16</b> ▶ <b>SNW 3128x4.15/16</b> ▶ <b>SNW 28x4.15/16</b>	N 028	W 028	HMVC 28E
	140	6,505	3,971	0,948	1,063	–	5,497	12	4		N 028	W 028	HMVC 28E
	140	7,099	3,971	0,948	1,063	–	5,497	12	4,75		AN 28	W 28	HMVC 28E
	140	7,099	5,313	0,948	1,063	–	5,497	12	5,9	▶ <b>SNW 128x4.15/16</b>	AN 28	W 28	HMVC 28E
<b>5</b> 127	140	6,505	3,33	0,948	1,063	–	5,497	12	3,8	▶ <b>SNW 3028x5</b> ▶ <b>SNW 3128x5</b> ▶ <b>SNW 28x5</b>	N 028	W 028	HMVC 28E
	140	6,505	3,971	0,948	1,063	–	5,497	12	4		N 028	W 028	HMVC 28E
	140	7,099	3,971	0,948	1,063	–	5,497	12	4,75		AN 28	W 28	HMVC 28E
	140	7,099	5,313	0,948	0,906	–	5,497	12	5,9	<b>SNW 128x5</b>	AN 28	W 28	HMVC 28E
<b>5 1/8</b> 130,175	150	7,13	3,482	0,979	1,094	–	5,888	12	4,45	<b>SNW 3030x5.1/8</b> <b>SNW 30x5.1/8</b> <b>SNW 130x5.1/8</b>	N 030	W 030	HMVC 30E
	150	7,693	4,231	0,979	1,125	–	5,888	12	7,25		AN 30	W 30	HMVC 30E
	150	7,693	5,611	0,979	1,125	–	5,888	12	8,15		AN 30	W 30	HMVC 30E
<b>5 3/16</b> 131,763	150	7,13	3,482	0,979	1,094	–	5,888	12	4,45	▶ <b>SNW 3030x5.3/16</b> ▶ <b>SNW 3130x5.3/16</b> ▶ <b>SNW 30x5.3/16</b>	N 030	W 030	HMVC 30E
	150	7,13	4,231	0,979	1,094	–	5,888	12	6,2		N 030	W 030	HMVC 30E
	150	7,693	4,231	0,979	1,125	–	5,888	12	7,25		AN 30	W 30	HMVC 30E
	150	7,693	5,611	0,979	1,125	–	5,888	12	8,15	▶ <b>SNW 130x5.3/16</b>	AN 30	W 30	HMVC 30E
<b>5 1/4</b> 133,35	150	7,13	3,482	0,979	1,094	–	5,888	12	4,45	<b>SNW 3030x5.1/4</b> ▶ <b>SNW 30x5.1/4</b> <b>SNW 130x5.1/4</b>	N 030	W 030	HMVC 30E
	150	7,693	4,231	0,979	1,125	–	5,888	12	7,25		AN 30	W 30	HMVC 30E
	150	7,693	5,611	0,979	1,125	–	5,888	12	8,15		AN 30	W 30	HMVC 30E

▶ Popular item

## 23.2 Adapter sleeves with inch dimensions

$d_1$  5 5/16 – 7 13/16 in.  
134,938 – 198,438 mm

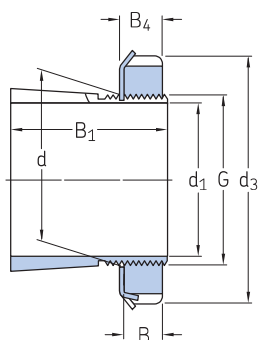

Principal dimensions							Thread	Mass	Designations	Included products		Associated	
$d_1$	$d$	$d_3$ max.	$B_1$	$B$	$B_4$	$B_5$	$G$	Threads per inch	Adapter sleeve assembly	lock nut	locking device	hydraulic nut	
in./mm	mm	in.					in.	–	–				
5 5/16 134,938	150	7,693	4,231	0,979	1,125	–	5,888	12	▶ SNW 30x5.5/16 SNW 130x5.5/16 SNW 136x5.5/16	AN 30	W 30	HMVC 30E	
	150	7,693	5,611	0,979	1,125	–	6,284	12		AN 30	W 30	HMVC 30E	
	180	9,068	6,446	1,104	1,104	–	7,066	8		AN 36	W 36	HMVC 36E	
5 3/8 136,525	150	7,693	4,231	0,979	1,125	–	5,888	12	SNW 30x5.3/8 SNW 130x5.3/8 SNW 3032x5.3/8	AN 30	W 30	HMVC 30E	
	150	7,693	5,611	0,979	1,125	–	6,284	12		AN 30	W 30	HMVC 30E	
	160	7,505	3,701	1,041	1,156	–	6,284	8		N 032	W 032	HMVC 32E	
	160	8,068	4,568	1,041	1,187	–	6,284	8	7,05	▶ SNW 32x5.3/8	AN 32	W 32	HMVC 32E
	160	8,068	5,91	1,041	1,187	–	6,284	8	8,15	▶ SNW 132x5.3/8	AN 32	W 32	HMVC 32E
	180	9,068	6,446	1,104	1,104	–	7,066	8	10	▶ SNW 136x5.3/8	AN 36	W 36	HMVC 36E
5 7/16 138,113	160	7,505	3,701	1,041	1,156	–	6,284	8	▶ SNW 3032x5.7/16 ▶ SNW 3132x5.7/16 ▶ SNW 32x5.7/16	N 032	W 032	HMVC 32E	
	160	7,505	4,568	1,041	1,156	–	6,284	8		6,1	N 032	W 032	HMVC 32E
	160	8,068	4,568	1,041	1,187	–	6,284	8		7,05	AN 32	W 32	HMVC 32E
	160	8,068	5,91	1,041	1,187	–	6,284	8	8,15	▶ SNW 132x5.7/16	AN 32	W 32	HMVC 32E
	160	8,068	5,91	1,041	1,187	–	6,284	8	8,15	▶ SNW 132x5.1/2	AN 32	W 32	HMVC 32E
5 1/2 139,7	160	7,505	3,701	1,041	1,156	–	6,284	8	SNW 3032x5.1/2 SNW 32x5.1/2 SNW 132x5.1/2	N 032	W 032	HMVC 32E	
	160	8,068	8,068	1,041	1,187	–	6,284	8		7,05	AN 32	W 32	HMVC 32E
	160	8,068	5,91	1,041	1,187	–	6,284	8		8,15	AN 32	W 32	HMVC 32E
5 3/4 146,05	160	8,068	4,568	1,041	1,187	–	6,284	8	7,05	▶ SNW 32x5.3/4	AN 32	W 32	HMVC 32E
5 13/16 147,638	170	7,88	4,009	1,073	1,188	–	6,659	8	SNW 3034x5.13/16 SNW 34x5.13/16 SNW 134x5.13/16	N 034	W 034	HMVC 34E	
	170	8,661	4,837	1,073	1,219	–	6,659	8		8,85	AN 34	W 34	HMVC 34E
	170	8,661	6,178	1,073	1,219	–	6,659	8		9,55	AN 34	W 34	HMVC 34E
5 7/8 149,225	170	7,88	4,009	1,073	1,188	–	6,659	8	SNW 3034x5.7/8 SNW 34x5.7/8 SNW 134x5.7/8	N 034	W 034	HMVC 34E	
	170	8,661	4,837	1,073	1,219	–	6,659	8		8,85	AN 34	W 34	HMVC 34E
	170	8,661	6,178	1,073	1,219	–	6,659	8		9,55	AN 34	W 34	HMVC 34E
5 15/16 150,813	170	7,88	4,009	1,073	1,188	–	6,659	8	▶ SNW 3034x5.15/16 ▶ SNW 3134x5.15/16 ▶ SNW 34x5.15/16 ▶ SNW 134x5.15/16	N 034	W 034	HMVC 34E	
	170	7,88	4,837	1,073	1,188	–	6,659	8		7,3	N 034	W 034	HMVC 34E
	170	8,661	4,837	1,073	1,219	–	6,659	8		8,85	AN 34	W 34	HMVC 34E
	170	8,661	6,178	1,073	1,219	–	6,659	8		9,55	AN 34	W 34	HMVC 34E
6 152,4	170	7,88	4,009	1,073	1,188	–	6,659	8	▶ SNW 3034x6 ▶ SNW 3134x6 ▶ SNW 34x6 ▶ SNW 134x6	N 034	W 034	HMVC 34E	
	170	7,88	4,837	1,073	1,188	–	6,659	8		7,3	N 034	W 034	HMVC 34E
	170	8,661	8,661	1,073	1,219	–	6,659	8		8,85	AN 34	W 34	HMVC 34E
	170	8,661	6,178	1,073	1,219	–	6,659	8		9,55	AN 34	W 34	HMVC 34E
	170	8,661	6,178	1,073	1,219	–	6,659	8		9,55	▶ SNW 134x6	AN 34	W 34
6 5/16 160,338	180	8,255	4,327	1,104	1,219	–	7,066	8	SNW 3036x6.5/16 SNW 36x6.5/16 SNW 136x6.5/16	N 036	W 036	HMVC 36E	
	180	9,068	5,028	1,104	1,25	–	7,066	8		9,3	AN 36	W 36	HMVC 36E
	180	9,068	6,446	1,104	6,3175	–	7,066	8		8,5	AN 36	W 36	HMVC 36E

▶ Popular item



Principal dimensions							Thread	Mass	Designations	Included products		Associated	
d <sub>1</sub>	d	d <sub>3</sub> max.	B <sub>1</sub>	B	B <sub>4</sub>	B <sub>5</sub>	G	Threads per inch	Adapter sleeve assembly	lock nut	locking device	hydraulic nut	
in./mm	mm	in.					in.	–	kg	–			
<b>6 3/8</b> 161,925	180	8,255	4,327	1,104	1,219	–	7,066	8	6,8	<b>SNW 3036x6.3/8</b>	N 036	W 036	HMVC 36E
	180	9,068	5,028	1,104	1,25	–	7,066	8	9,3	<b>SNW 36x6.3/8</b>	AN 36	W 36	HMVC 36E
	180	9,068	6,446	1,104	1,104	–	7,066	8	10	<b>SNW 136x6.3/8</b>	AN 36	W 36	HMVC 36E
<b>6 7/16</b> 163,513	180	8,255	4,327	1,104	1,219	–	7,066	8	6,8	▶ <b>SNW 3036x6.7/16</b>	N 036	W 036	HMVC 36E
	180	8,255	5,028	1,104	1,219	–	7,066	8	7,75	▶ <b>SNW 3136x6.7/16</b>	N 036	W 036	HMVC 36E
	180	9,068	5,028	1,104	1,25	–	7,066	8	9,3	▶ <b>SNW 36x6.7/16</b>	AN 36	W 36	HMVC 36E
	180	9,068	6,446	1,104	1,25	–	7,066	8	10	▶ <b>SNW 136x6.7/16</b>	AN 36	W 36	HMVC 36E
<b>6 1/2</b> 165,1	180	8,255	4,327	1,104	1,219	–	7,066	8	6,8	<b>SNW 3036x6.1/2</b>	N 036	W 036	HMVC 36E
	180	8,255	5,028	1,104	1,219	–	7,066	8	7,75	<b>SNW 3136x6.1/2</b>	N 036	W 036	HMVC 36E
	180	9,068	5,028	1,104	1,25	–	7,066	8	9,3	▶ <b>SNW 36x6.1/2</b>	AN 36	W 36	HMVC 36E
	180	9,068	6,446	1,104	1,104	–	7,066	8	10	<b>SNW 136x6.1/2</b>	AN 36	W 36	HMVC 36E
<b>6 13/16</b> 173,038	190	8,693	4,402	1,135	1,25	–	7,472	8	7,5	<b>SNW 3038x6.13/16</b>	N 038	W 038	HMVC 38E
	190	9,474	5,251	1,135	1,281	–	7,472	8	10,5	<b>SNW 38x6.13/16</b>	AN 38	W 38	HMVC 38E
	190	9,474	6,748	1,135	1,281	–	7,472	8	12,5	<b>SNW 138x6.13/16</b>	AN 38	W 38	HMVC 38E
<b>6 7/8</b> 174,625	190	8,693	4,402	1,135	1,25	–	7,472	8	7,5	<b>SNW 3038x6.7/8</b>	N 038	W 038	HMVC 38E
	190	9,474	5,251	1,135	1,281	–	7,472	8	10,5	<b>SNW 38x6.7/8</b>	AN 38	W 38	HMVC 38E
	190	9,474	6,748	1,135	1,281	–	7,472	8	12,5	<b>SNW 138x6.7/8</b>	AN 38	W 38	HMVC 38E
<b>6 15/16</b> 176,213	180	9,068	6,446	1,104	1,104	–	7,066	8	10	<b>SNW 136x6.15/16</b>	AN 36	W 36	HMVC 36E
	190	8,693	4,402	1,135	1,25	–	7,472	8	7,5	▶ <b>SNW 3038x6.15/16</b>	N 038	W 038	HMVC 38E
	190	8,693	5,251	1,135	1,25	–	7,472	8	8,95	▶ <b>SNW 3138x6.15/16</b>	N 038	W 038	HMVC 38E
	190	9,474	5,251	1,135	1,281	–	7,472	8	10,5	▶ <b>SNW 38x6.15/16</b>	AN 38	W 38	HMVC 38E
	190	9,474	6,748	1,135	1,281	–	7,472	8	12,5	▶ <b>SNW 138x6.15/16</b>	AN 38	W 38	HMVC 38E
<b>7</b> 177,8	190	8,693	4,402	1,135	1,25	–	7,472	8	7,5	▶ <b>SNW 3038x7</b>	N 038	W 038	HMVC 38E
	190	8,693	5,251	1,135	1,25	–	7,472	8	8,95	▶ <b>SNW 3138x7</b>	N 038	W 038	HMVC 38E
	190	9,474	5,251	1,135	1,281	–	7,472	8	10,5	▶ <b>SNW 38x7</b>	AN 38	W 38	HMVC 38E
	190	9,474	6,748	1,135	1,281	–	7,472	8	12,5	▶ <b>SNW 138x7</b>	AN 38	W 38	HMVC 38E
<b>7 1/8</b> 180,975	20	9,849	7,085	1,198	1,344	–	7,847	8	16	<b>SNW 140x7.1/8</b>	AN 40	W 40	HMVC 40E
	200	9,443	4,74	1,198	1,313	–	7,847	8	8,85	<b>SNW 3040x7.1/8</b>	N 040	W 040	HMVC 40E
	200	9,849	5,474	1,198	1,344	–	7,847	8	14	<b>SNW 40x7.1/8</b>	AN 40	W 40	HMVC 40E
<b>7 3/16</b> 182,563	200	9,443	4,74	1,198	1,313	–	7,847	8	8,85	▶ <b>SNW 3040x7.3/16</b>	N 040	W 040	HMVC 40E
	200	9,443	5,474	1,198	1,313	–	7,847	8	13	▶ <b>SNW 3140x7.3/16</b>	N 040	W 040	HMVC 40E
	200	9,849	5,474	1,198	1,344	–	7,847	8	14	▶ <b>SNW 40x7.3/16</b>	AN 40	W 40	HMVC 40E
	200	9,849	7,085	1,198	1,344	–	7,847	8	16	▶ <b>SNW 140x7.3/16</b>	AN 40	W 40	HMVC 40E
<b>7 1/4</b> 184,15	220	11,005	7,227	1,26	1,406	–	8,628	8	21	<b>SNW 144x7.3/16</b>	N 44	W 44	HMVC 44E
	200	9,849	7,085	1,198	1,344	–	7,847	8	16	<b>SNW 140x7.1/4</b>	AN 40	W 40	HMVC 40E
	200	9,443	4,74	1,198	1,313	–	7,847	8	8,85	<b>SNW 3040x7.1/4</b>	N 040	W 040	HMVC 40E
<b>7 7/16</b> 188,913	200	9,849	5,474	1,198	1,344	–	7,847	8	14	<b>SNW 40x7.1/4</b>	AN 40	W 40	HMVC 40E
	200	9,443	4,74	1,198	1,313	–	7,847	8	8,85	<b>SNW 3040x7.7/16</b>	N 040	W 040	HMVC 40E
	200	9,849	7,085	1,198	1,344	–	7,847	8	16	<b>SNW 140x7.3/16</b>	AN 40	W 40	HMVC 40E
<b>7 1/2</b> 190,5	220	11,005	7,227	1,26	1,406	–	8,628	8	14,5	<b>SNW 44x7.1/2</b>	N 44	W 44	HMVC 44E
	220	11,005	7,227	1,26	1,406	–	8,628	8	21	<b>SNW 144x7.1/2</b>	N 44	W 44	HMVC 44E
<b>7 13/16</b> 198,438	200	9,849	7,085	1,198	1,344	–	7,847	8	16	<b>SNW 140x7.13/16</b>	AN 40	W 40	HMVC 40E
	220	10,255	5,12	1,26	1,375	–	8,628	8	11	<b>SNW 3044x7.13/16</b>	N 044	W 044	HMVC 44E
	220	11,005	5,891	1,26	1,406	–	8,628	8	14,5	<b>SNW 44x7.13/16</b>	N 44	W 44	HMVC 44E
	220	11,005	7,227	1,26	1,406	–	8,628	8	21	<b>SNW 144x7.13/16</b>	N 44	W 44	HMVC 44E
	220	11,005	7,227	1,26	1,406	–	8,628	8	21	<b>SNW 144x7.13/16</b>	N 44	W 44	HMVC 44E

▶ Popular item



## 23.2 Adapter sleeves with inch dimensions

$d_1$  7 7/8 – 16 1/2 in.  
200,025 – 419,1 mm

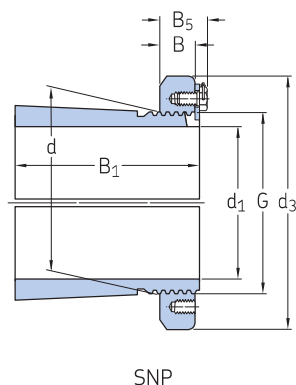
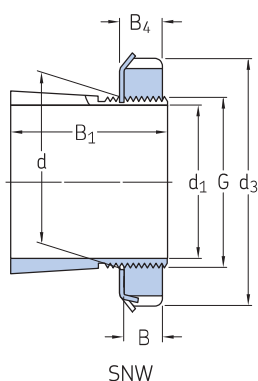

Principal dimensions							Thread	Mass	Designations	Included products		Associated
$d_1$	d	$d_3$ max.	$B_1$	B	$B_4$	$B_5$	G	Threads per inch	Adapter sleeve assembly	lock nut	locking device	hydraulic nut
in./mm	mm	in.					in.	–	–			
7 7/8 200,025	200	9,849	7,085	1,198	1,344	–	7,847	8	SNW 140x7.7/8	AN 40	W 40	HMVC 40E
	220	10,255	5,12	1,26	1,375	–	8,628	8	SNW 3044x7.7/8	N 044	W 044	HMVC 44E
	220	11,005	5,891	1,26	1,406	–	8,628	8	SNW 44x7.7/8	N 44	W 44	HMVC 44E
	220	11,005	7,227	1,26	1,406	–	8,628	8	SNW 144x7.7/8	N 44	W 44	HMVC 44E
7 15/16 201,613	220	10,255	5,12	1,26	1,375	–	8,628	8	▶ SNW 3044x7.15/16	N 044	W 044	HMVC 44E
	220	10,255	5,891	1,26	1,375	–	8,628	8	▶ SNW 3144x7.15/16	N 044	W 044	HMVC 44E
	220	11,005	5,891	1,26	1,406	–	8,628	8	▶ SNW 44x7.15/16	N 44	W 44	HMVC 44E
	220	11,005	7,277	1,26	1,406	–	8,628	8	▶ SNW 144x7.15/16	N 44	W 44	HMVC 44E
8 203,2	200	9,849	7,085	1,198	1,344	–	7,847	8	SNW 140x8	AN 40	W 40	HMVC 40E
	220	10,255	5,12	1,26	1,375	–	8,628	8	▶ SNW 3044x8	N 044	W 044	HMVC 44E
	220	10,255	5,891	1,26	1,375	–	8,628	8	▶ SNW 3144x8	N 044	W 044	HMVC 44E
	220	11,005	5,891	1,26	1,406	–	8,628	8	▶ SNW 44x8	N 44	W 44	HMVC 44E
220	11,005	7,227	1,26	1,406	–	8,628	8	SNW 144x8	N 44	W 44	HMVC 44E	
8 7/16 214,313	240	11,443	5,422	1,354	–	1,698	9,442	6	SNP 3048x8.7/16	N 048	PL 48	HMVC 48E
	240	11,443	5,422	1,354	–	1,698	9,442	6	SNP 3048x8.1/2	N 048	PL 48	HMVC 48E
8 15/16 227,013	240	11,443	5,422	1,354	–	1,698	9,442	6	▶ SNP 3048x8.15/16	N 048	PL 48	HMVC 48E
	240	11,443	6,628	1,354	–	1,698	9,442	6	▶ SNP 3148x8.15/16	N 048	PL 48	HMVC 48E
	240	11,443	8,099	1,354	–	1,698	9,442	6	▶ SNP 148x8.15/16	N 048	PL 48	HMVC 48E
9 228,6	240	11,443	5,422	1,354	–	1,698	9,442	6	SNP 3048x9	N 048	PL 48	HMVC 48E
	240	12,193	8,764	1,416	–	1,76	10,192	6	▶ SNP 3152x9	N 052	PL 52	HMVC 52E
	260	12,193	8,764	1,416	–	1,76	10,192	6	SNP 152x9	N 052	PL 52	HMVC 52E
9 7/16 239,713	260	12,193	6,009	1,416	–	1,76	10,192	6	▶ SNP 3052x9.7/16	N 052	PL 52	HMVC 52E
	260	12,193	8,764	1,416	–	1,76	10,192	6	▶ SNP 3152x9.7/16	N 052	PL 52	HMVC 52E
	260	12,193	8,764	1,416	–	1,76	10,192	6	▶ SNP 152x9.7/16	N 052	PL 52	HMVC 52E
9 1/2 241,3	260	12,193	6,009	1,416	–	1,76	10,192	6	▶ SNP 3052x9.1/2	N 052	PL 52	HMVC 52E
	260	12,193	8,764	1,416	–	1,76	10,192	6	▶ SNP 3152x9.1/2	N 052	PL 52	HMVC 52E

▶ Popular item

Principal dimensions							Thread	Mass	Designations	Included products	Associated	
d <sub>1</sub>	d	d <sub>3</sub> max.	B <sub>1</sub>	B	B <sub>4</sub>	B <sub>5</sub>	G	Threads per inch	Adapter sleeve assembly	lock nut	locking device	hydraulic nut
in./mm	mm	in.					in.	–	–			
<b>9 15/16</b> 252,413	280	13,005	6,181	1,51	–	1,854	11,004	6	▶ SNP 3056x9.15/16	N 056	PL 56	HMVC 56E
	280	13,005	7,756	1,51	–	1,854	11,004	6	▶ SNP 3156x9.15/16	N 056	PL 56	HMVC 56E
<b>10</b> 254	280	13,005	6,181	1,51	–	1,854	11,004	6	▶ SNP 3056x10	N 056	PL 56	HMVC 56E
	280	13,005	7,756	1,51	–	1,854	11,004	6	▶ SNP 3156x10	N 056	PL 56	HMVC 56E
<b>10 7/16</b> 265,113	280	13,005	6,181	1,51	–	1,854	11,004	6	▶ SNP 3056x10.7/16	N 056	PL 56	HMVC 56E
	280	13,005	7,756	1,51	–	1,854	11,004	6	▶ SNP 3156x10.7/16	N 056	PL 56	HMVC 56E
	280	13,005	8,937	1,51	–	1,854	11,004	6	▶ SNP 3256x10.7/16	N 056	PL 56	HMVC 56E
<b>10 1/2</b> 266,7	280	13,005	6,181	1,51	–	1,854	11,004	6	▶ SNP 3056x10.1/2	N 056	PL 56	HMVC 56E
	280	13,005	7,756	1,51	–	1,854	11,004	6	▶ SNP 3156x10.1/2	N 056	PL 56	HMVC 56E
<b>10 15/16</b> 277,813	300	14,193	6,717	1,573	–	1,948	11,785	6	▶ SNP 3060x10.15/16	N 060	PL 60	HMVC 60E
	300	14,193	8,37	1,573	–	1,948	11,785	6	▶ SNP 3160x10.15/16	N 060	PL 60	HMVC 60E
	300	14,193	9,63	1,573	–	1,948	11,785	6	▶ SNP 3260x10.15/16	N 060	PL 60	HMVC 60E
<b>11</b> 279,4	300	14,193	6,717	1,573	–	1,948	11,785	6	▶ SNP 3060x11	N 060	PL 60	HMVC 60E
	300	14,193	9,63	1,573	–	1,948	11,785	6	▶ SNP 3260x11	N 060	PL 60	HMVC 60E
<b>11 7/16</b> 290,513	320	15,005	6,936	1,666	–	2,041	12,562	6	▶ SNP 3064x11.7/16	N 064	PL 64	HMVC 64E
<b>11 1/2</b> 292,1	320	15,005	6,936	1,666	–	2,041	12,562	6	▶ SNP 3064x11.1/2	N 064	PL 64	HMVC 64E
<b>11 15/16</b> 303,213	320	15,005	6,936	1,666	–	2,041	12,562	6	▶ SNP 3064x11.15/16	N 064	PL 64	HMVC 64E
	320	15,005	9,101	1,666	–	2,041	12,562	6	▶ SNP 3164x11.15/16	N 064	PL 64	HMVC 64E
	320	15,005	10,361	1,666	–	2,041	12,562	6	▶ SNP 3264x11.15/16	N 064	PL 64	HMVC 64E
<b>12</b> 304,8	320	15,005	6,936	1,666	–	2,041	12,562	6	▶ SNP 3064x12	N 064	PL 64	HMVC 64E
	320	15,005	9,101	1,666	–	2,041	12,562	6	▶ SNP 3164x12	N 064	PL 64	HMVC 64E
	320	15,005	10,361	1,666	–	2,041	12,562	6	▶ SNP 3264x12	N 064	PL 64	HMVC 64E
<b>12 7/16</b> 315,913	340	15,755	7,533	1,791	–	2,166	13,303	5	▶ SNP 3068x12.7/16	N 068	PL 68	HMVC 68E
	340	15,755	9,777	1,791	–	2,166	13,303	5	▶ SNP 3168x12.7/16	N 068	PL 68	HMVC 68E
	340	15,755	11,116	1,791	–	2,166	13,303	5	▶ SNP 3268x12.7/16	N 068	PL 68	HMVC 68E
<b>13 7/16</b> 341,313	360	16,505	7,569	1,791	–	2,166	14,17	5	▶ SNP 3072x13.7/16	N 072	PL 72	HMVC 72E
	360	16,505	9,852	1,791	–	2,166	14,17	5	▶ SNP 3172x13.7/16	N 072	PL 72	HMVC 72E
	360	16,505	11,427	1,791	–	2,166	14,17	5	▶ SNP 3272x13.7/16	N 072	PL 72	HMVC 72E
<b>13 15/16</b> 354,013	360	16,505	7,569	1,791	–	2,166	14,17	5	▶ SNP 3072x13.15/16	N 072	PL 72	HMVC 72E
	360	17,755	11,867	1,916	–	2,353	14,921	5	▶ SNP 3276x13.15/16	N 076	PL 76	HMVC 76E
	380	17,755	7,733	1,916	–	2,353	14,921	5	▶ SNP 3076x13.15/16	N 076	PL 76	HMVC 76E
	380	17,755	10,056	1,916	–	2,353	14,921	5	▶ SNP 3176x13.15/16	N 076	PL 76	HMVC 76E
<b>14</b> 355,6	360	17,755	11,867	1,916	–	2,353	14,921	5	▶ SNP 3276x14	N 076	PL 76	HMVC 76E
	380	17,755	7,733	1,916	–	2,353	14,921	5	▶ SNP 3076x14	N 076	PL 76	HMVC 76E
	380	17,755	10,056	1,916	–	2,353	14,921	5	▶ SNP 3176x14	N 076	PL 76	HMVC 76E
<b>14 15/16</b> 379,413	400	18,505	10,449	2,073	–	2,5	15,709	5	▶ SNP 3180x14.15/16	N 080	PL 80	HMVC 80E
<b>15</b> 381	400	18,505	8,401	2,073	–	2,5	15,709	5	▶ SNP 3080x15	N 080	PL 80	HMVC 80E
	400	18,505	10,449	2,073	–	2,5	15,709	5	▶ SNP 3180x15	N 080	PL 80	HMVC 80E
	400	18,505	12,654	2,073	–	2,5	15,709	5	▶ SNP 3280x15	N 080	PL 80	HMVC 80E
<b>15 3/4</b> 400,05	420	19,318	8,488	2,073	–	2,5	16,496	5	▶ SNP 3084x15.3/4	N 084	PL 84	HMVC 84E
	420	19,318	11,402	2,073	–	2,5	16,496	5	▶ SNP 3184x15.3/4	N 084	PL 84	HMVC 84E
	420	19,318	13,292	2,073	–	2,5	16,496	5	▶ SNP 3284x15.3/4	N 084	PL 84	HMVC 84E
<b>16 1/2</b> 419,1	440	20,505	9,1	2,385	–	2,906	17,283	5	▶ SNP 3088x16.1/2	N 088	PL 88	HMVC 88E
	440	20,505	11,817	2,385	–	2,906	17,283	5	▶ SNP 3188x16.1/2	N 088	PL 88	HMVC 88E
	440	20,505	13,943	2,385	–	2,906	17,283	5	▶ SNP 3288x16.1/2	N 088	PL 88	HMVC 88E

▶ Popular item





## 23.2 Adapter sleeves with inch dimensions

$d_1$  17 – 19 1/2 in.  
431,8 – 495,3 mm

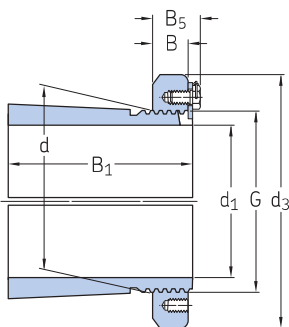

Principal dimensions							Thread	Mass	Designations	Included products		Associated	
$d_1$	$d$	$d_3$ max.	$B_1$	$B$	$B_4$	$B_5$	$G$	Threads per inch	Adapter sleeve assembly	lock nut	locking device	hydraulic nut	
in./mm	mm	in.					in.	–	–				
<b>17</b> 431,8	460	21,255	9,336	2,385	–	2,906	18,071	5	71,5	▶ <b>SNP 3092x17</b>	N 092	PL 92	HMVC 92E
	460	21,255	12,368	2,385	–	2,906	18,071	5	95	▶ <b>SNP 3192x17</b>	N 092	PL 92	HMVC 92E
<b>18</b> 457,2	480	22,068	12,714	2,385	–	2,937	18,858	5	75	▶ <b>SNP 3096x18</b>	N 096	PL 96	HMVC 96E
	480	22,068	12,714	2,385	–	2,937	18,858	5	91,5	▶ <b>SNP 3196x18</b>	N 096	PL 96	HMVC 96E
<b>18 1/2</b> 469,9	500	22,818	9,838	2,703	–	3,25	19,646	5	91	▶ <b>SNP 30/500x18.1/2</b>	N 500	PL 500	HMVC 100E
<b>19 1/2</b> 495,3	530	24,818	10,579	2,703	–	3,25	20,827	4	120	▶ <b>SNP 30/530x19.1/2</b>	N 530	PL 530	HMVC 106E





24

## Withdrawal sleeves

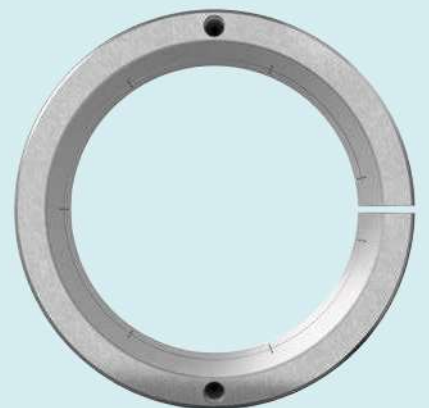
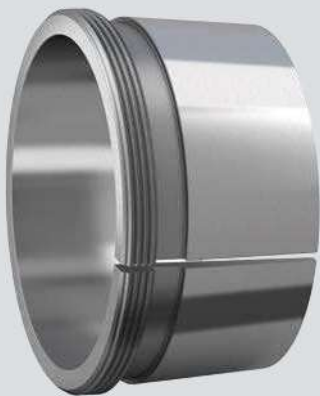

# 24 Withdrawal sleeves

Withdrawal sleeves are slit tapered sleeves (fig. 1), which can be used to mount bearings with a tapered bore onto a cylindrical seat of stepped shafts (fig. 2). The sleeves are pressed into the bore of the bearing inner ring, which abuts a shaft shoulder or similar fixed component. They are located on the shaft by a nut or an end plate.

The standard assortment of SKF withdrawal sleeves is available online at [skf.com/go/17000-24-1](https://skf.com/go/17000-24-1) and comprises:

- basic design sleeves (fig. 1)
- sleeves for oil injection (fig. 3)
- sleeves for shaft diameters up to 1 000 mm

Withdrawal sleeves are not listed in this catalogue. Comprehensive information about SKF withdrawal sleeves is available online at [skf.com/go/17000-24](https://skf.com/go/17000-24).

Fig. 1

Withdrawal sleeve, basic design

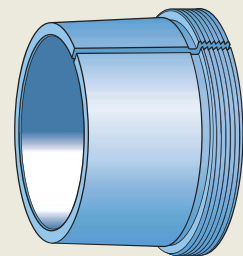

Fig. 2

Withdrawal sleeve on a stepped shaft

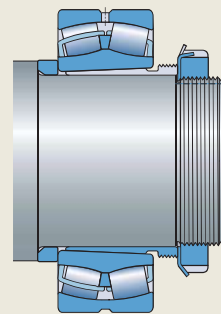
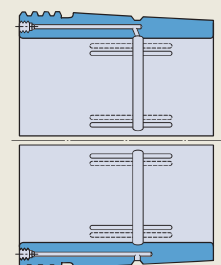

Fig. 3

Withdrawal sleeve for oil injection





25

# Lock nuts

